

# Athena 2 LM-004

Launched the Lunar Prospector  
on January 7, 1998.

**LOCKHEED MARTIN**  
Lockheed Martin Launch Vehicles.

## Scale 1:96



color other side grey

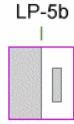
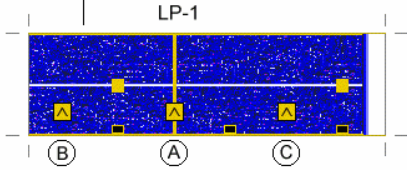

cut out this part (in the white area)

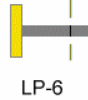

LP-6

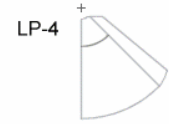
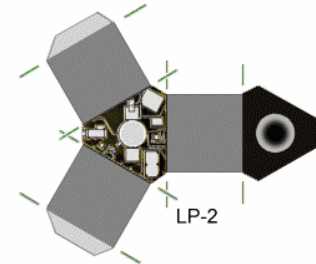
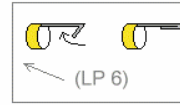

LP-4

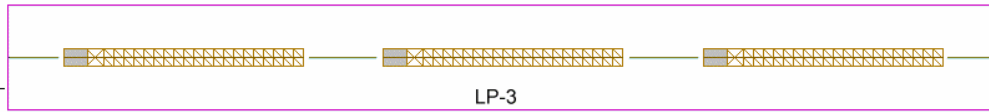

LP-3

1: Score along green lines 2: make nice sharp fold, then unfold and lay out flat 3: carefully cut out parts



\* spare

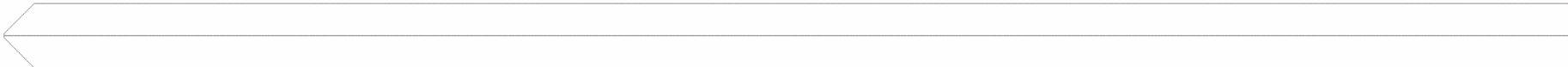

Part A 2

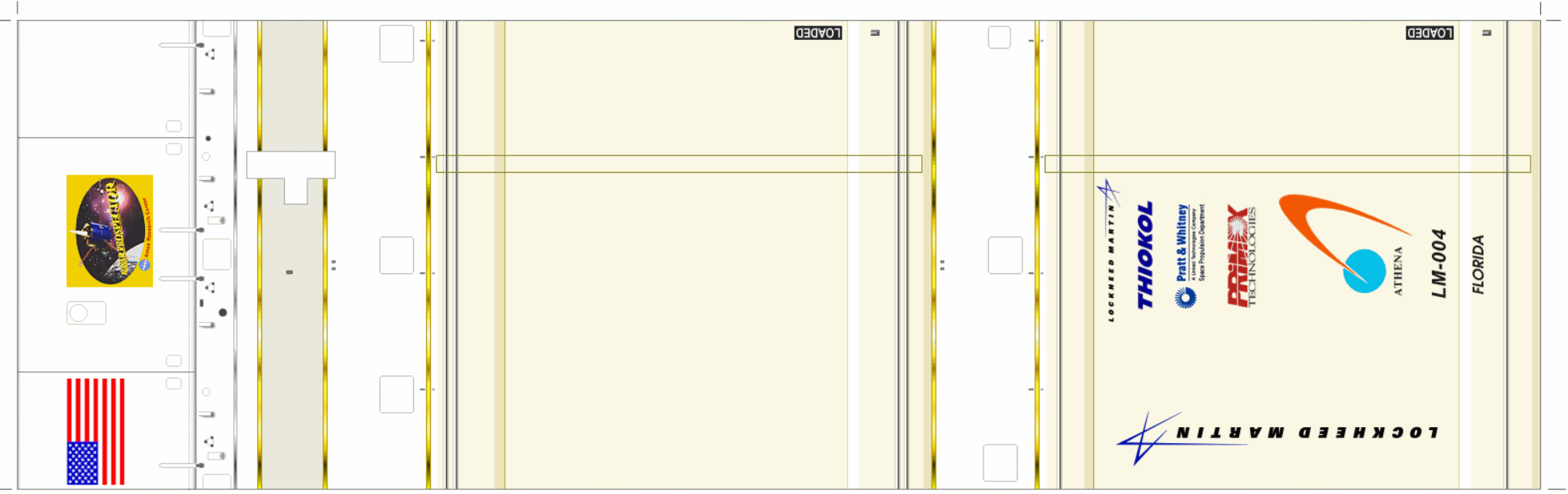

Part A

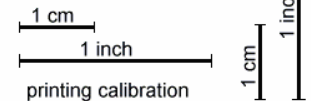

# Athena 2 LM-004



**Scale 1:96**

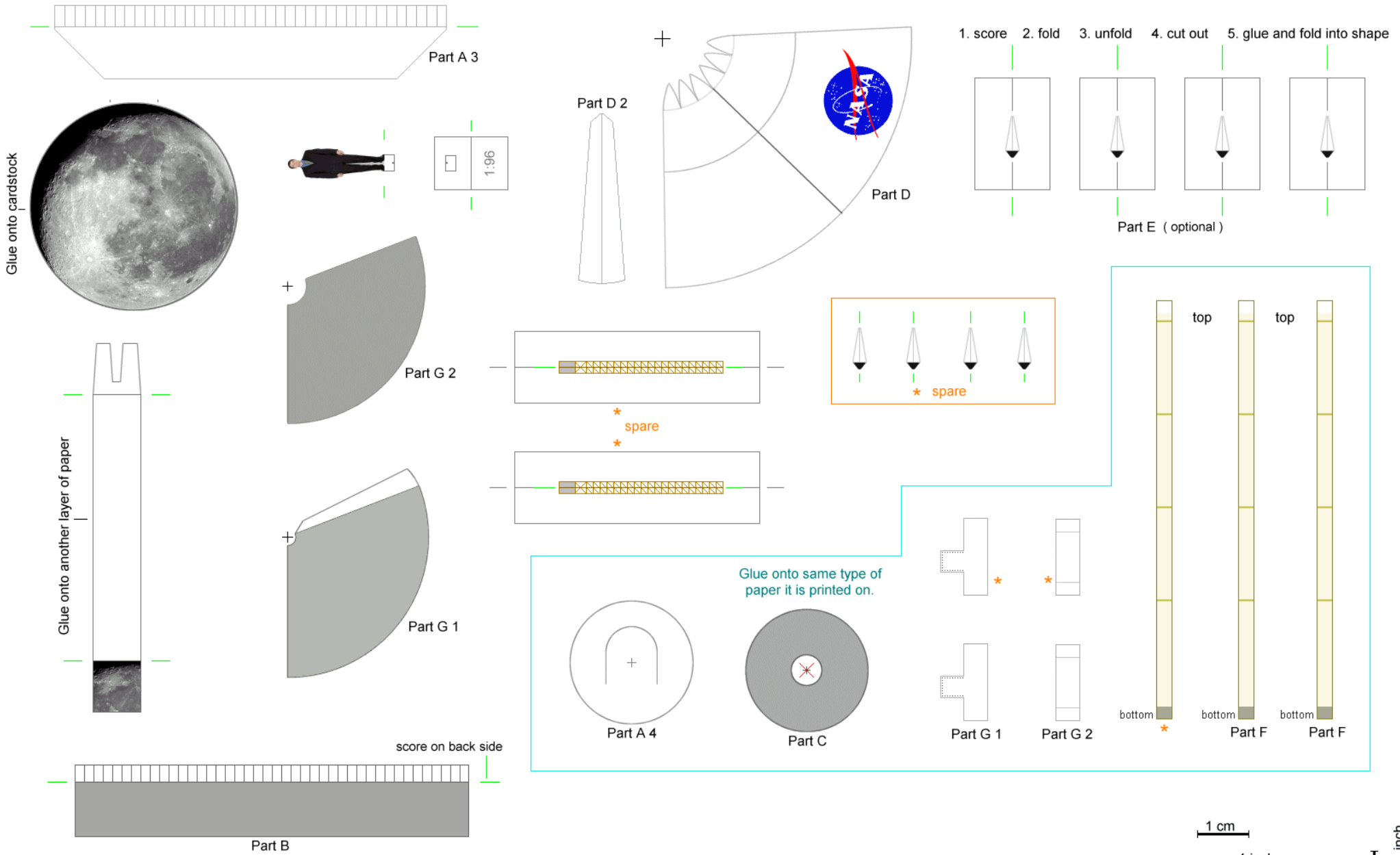

# Instructions for building the Athena 2 rocket.

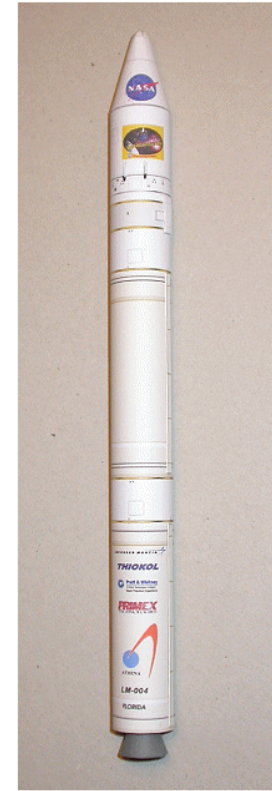
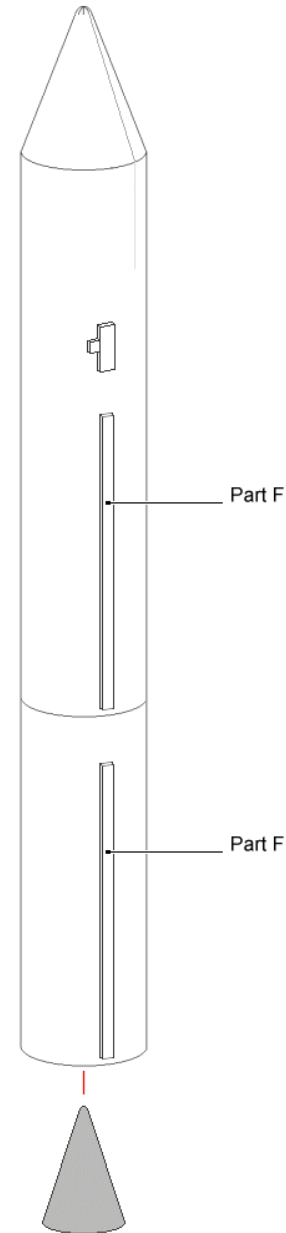
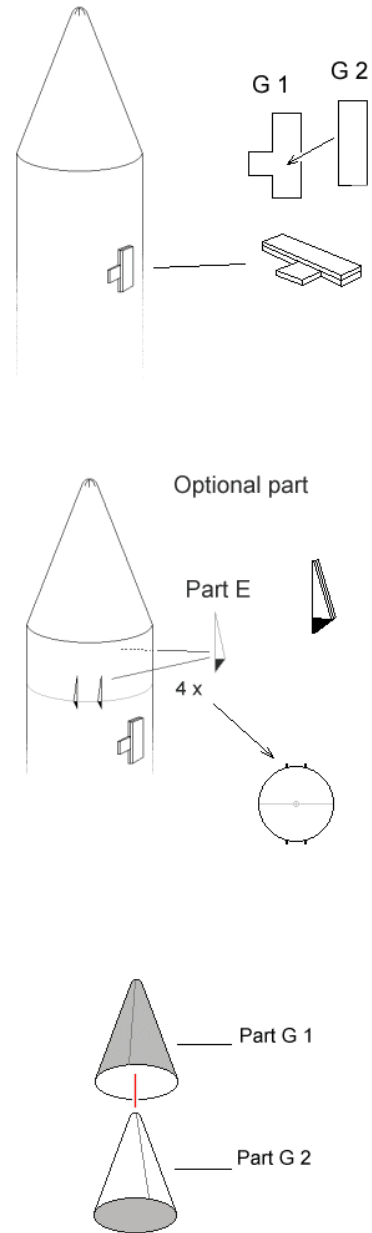
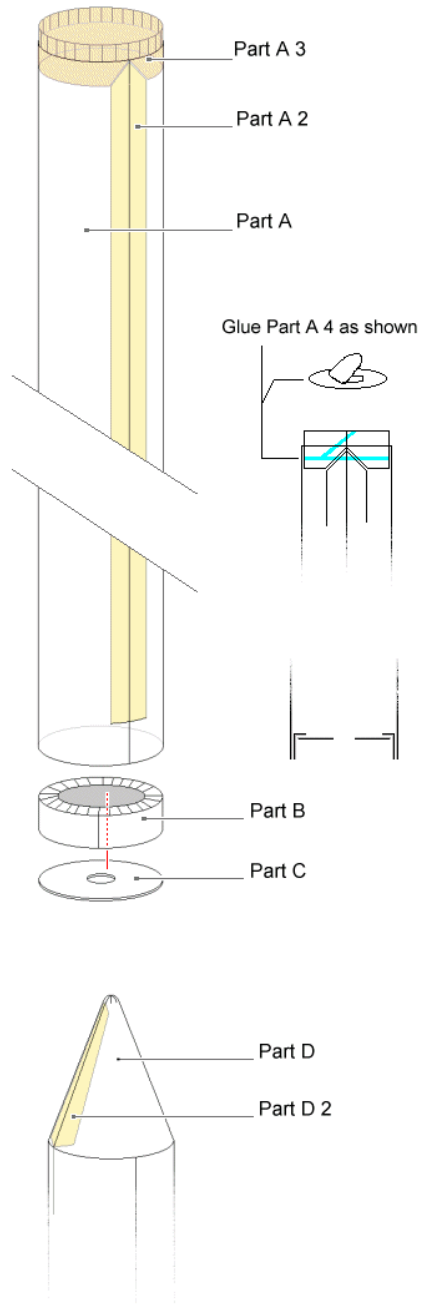

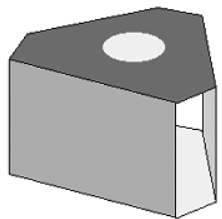
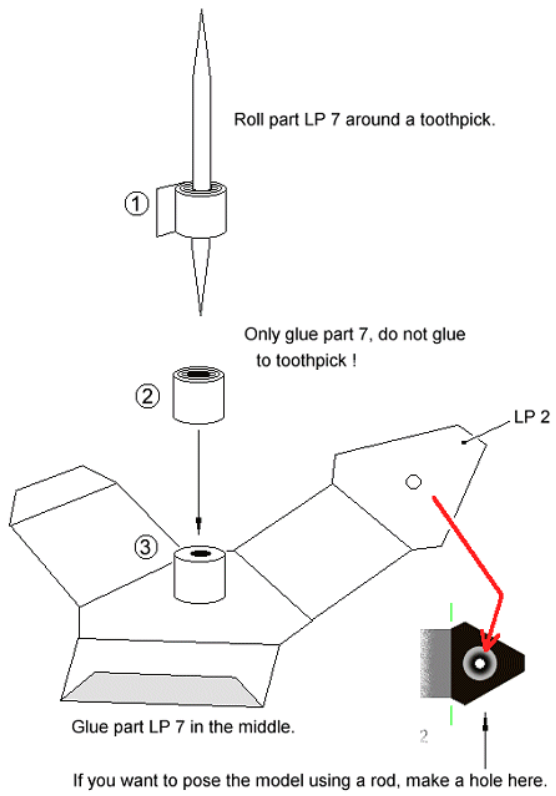

Now assemble part LP 2

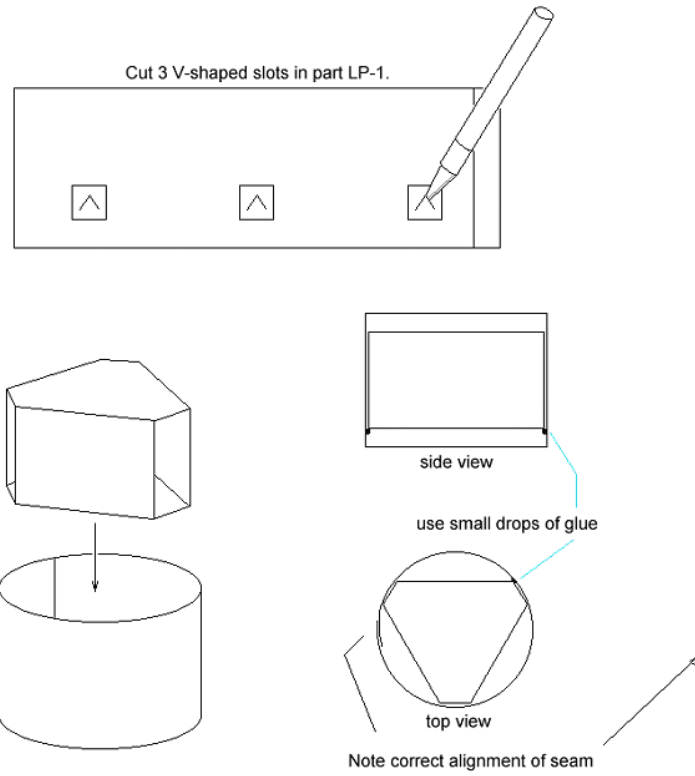

Part LP 4

