

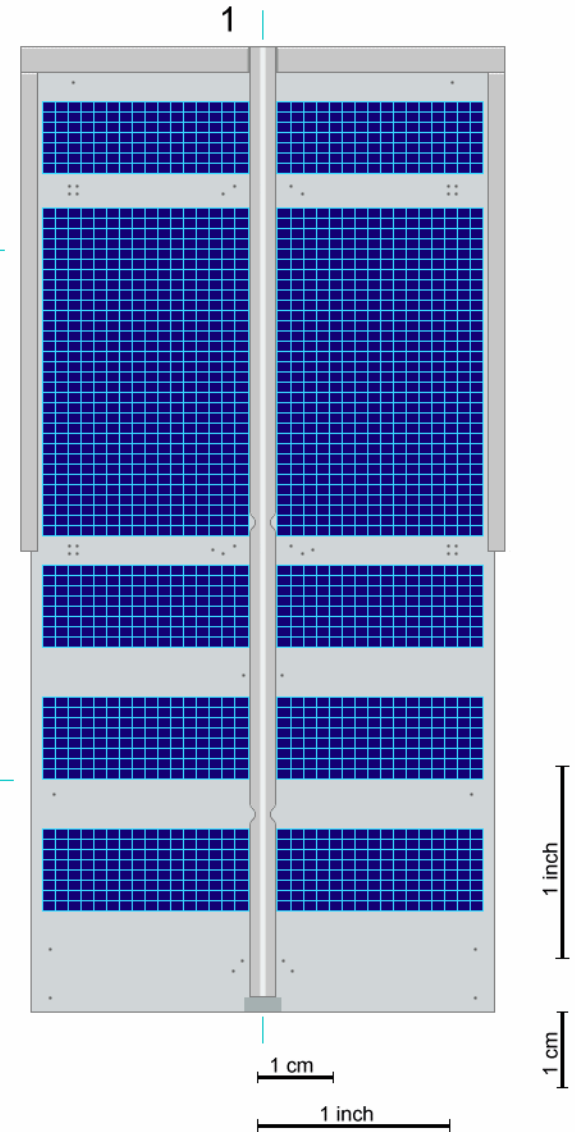

The new space telescope
for infrared observation.

Scale 1:25

Page 1/7

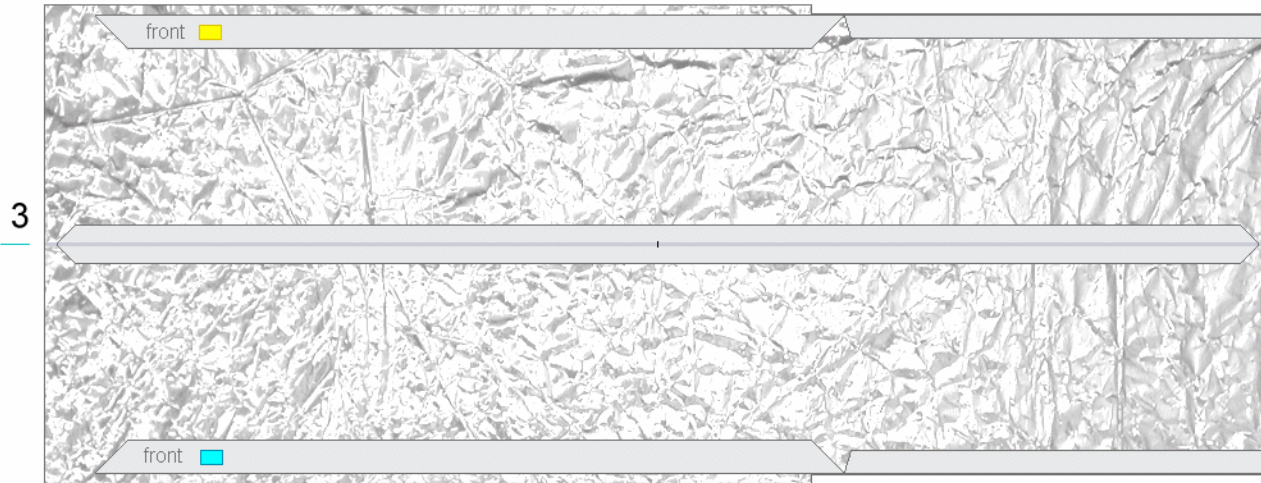

Paper model version by E. te Groen. For the Public Observatory Philippus Lansbergen, Netherlands.

Do not copy. Not for commercial purposes. For private use only.

www.lansbergen.net

(c) 2003

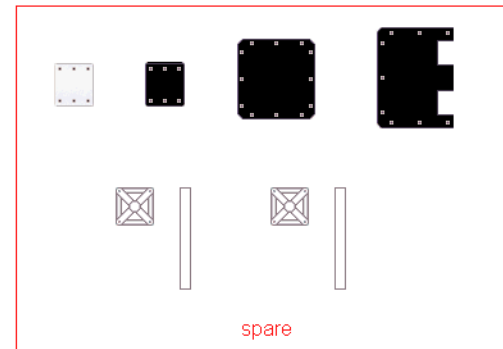
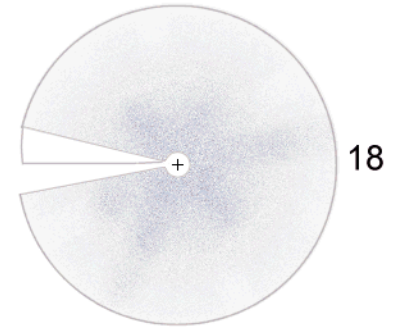
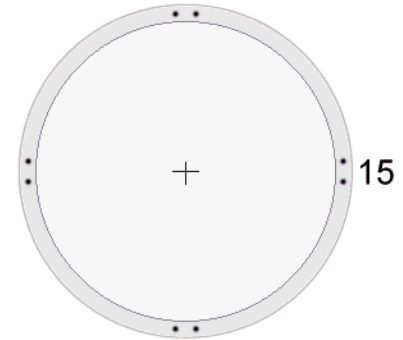
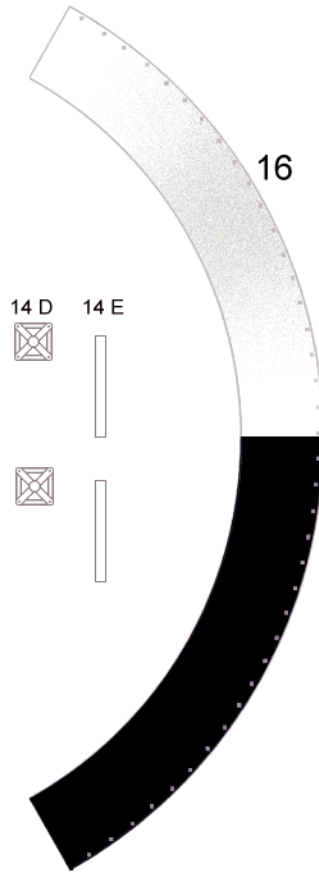
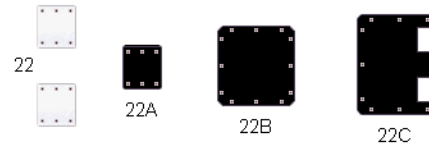
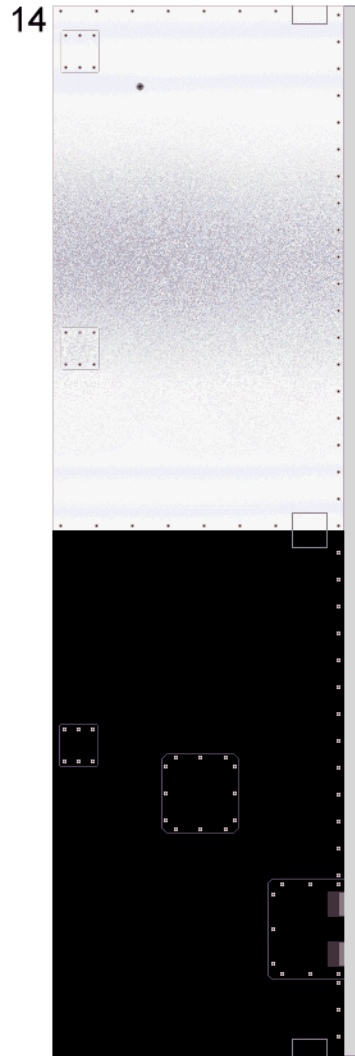
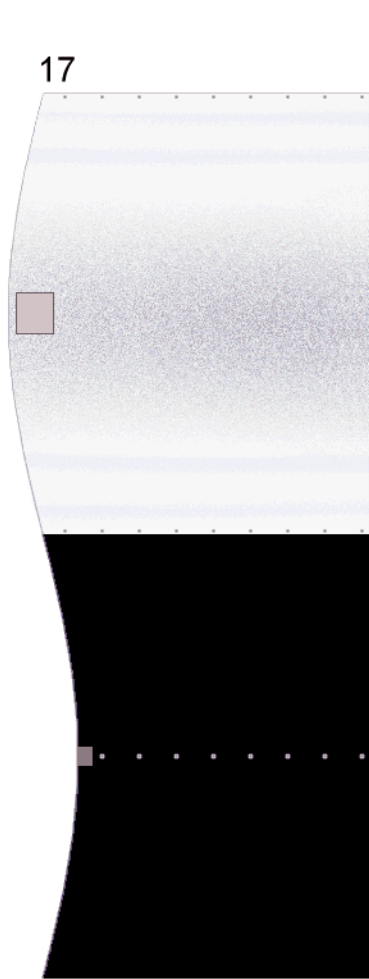

1 inch
1 cm

1 cm 1 inch

The new space telescope
for infrared observation.



Scale 1:25

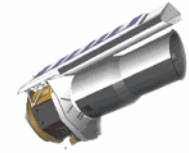

Page 3/7

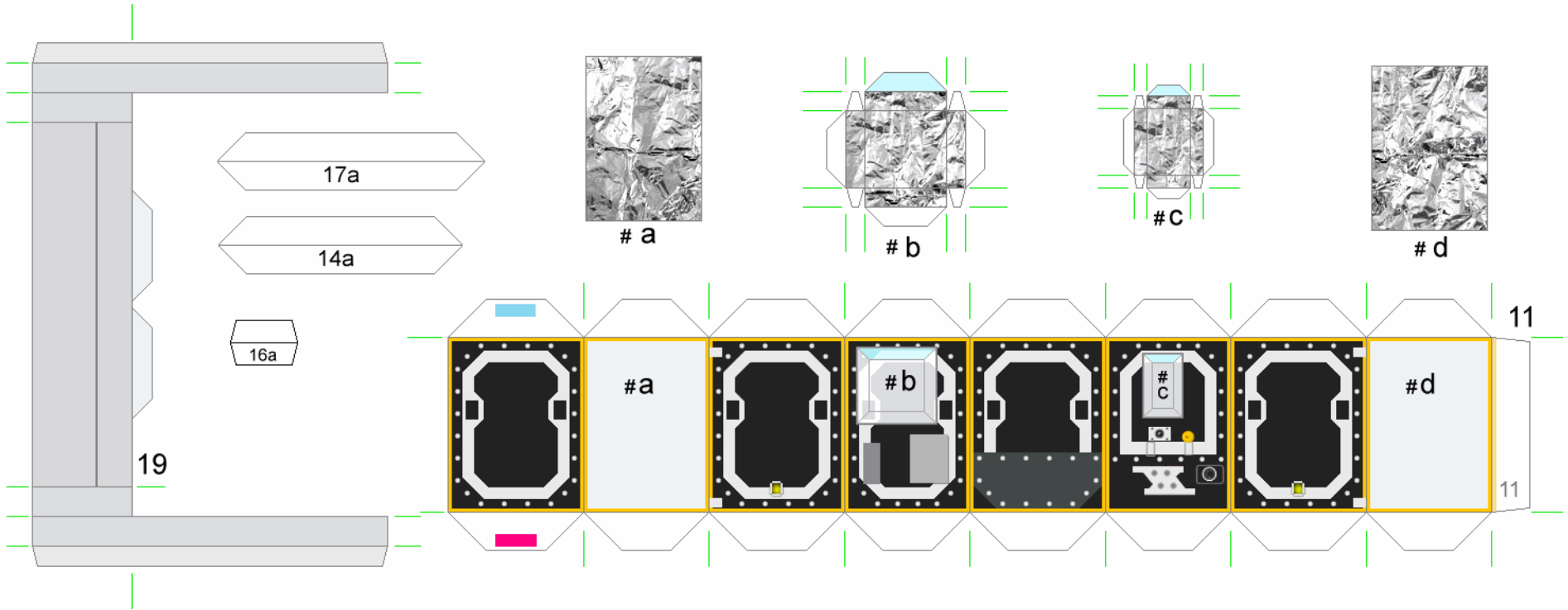

Make this shape.



Roll up, to double thickness.

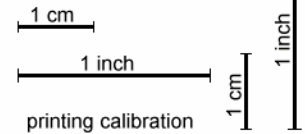

Paper model version by E. te Groen. For the Public Observatory Philippus Lansbergen, Netherlands.

Do not copy. Not for commercial purposes. For private use only.

www.lansbergen.net

(c) 2003

The new space telescope
for infrared observation.



Scale 1:25

Page 4/7

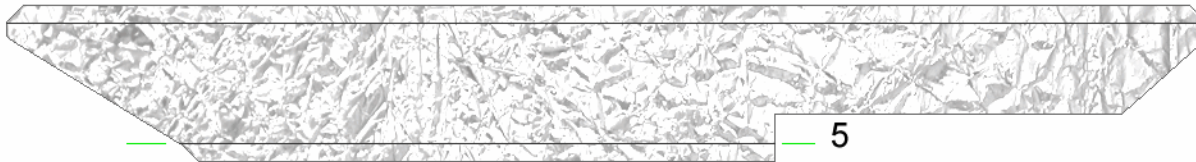

5

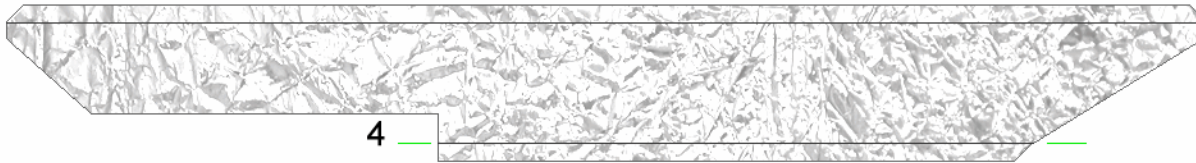

4

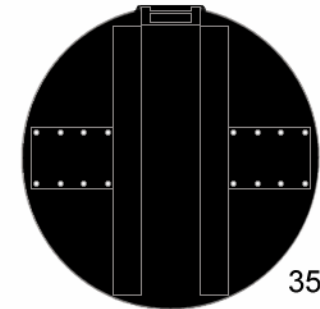

35

Dust cover.
One time use. Is ejected
once in space.
Glue onto cardstock
Keep the rim white or paint it silver.

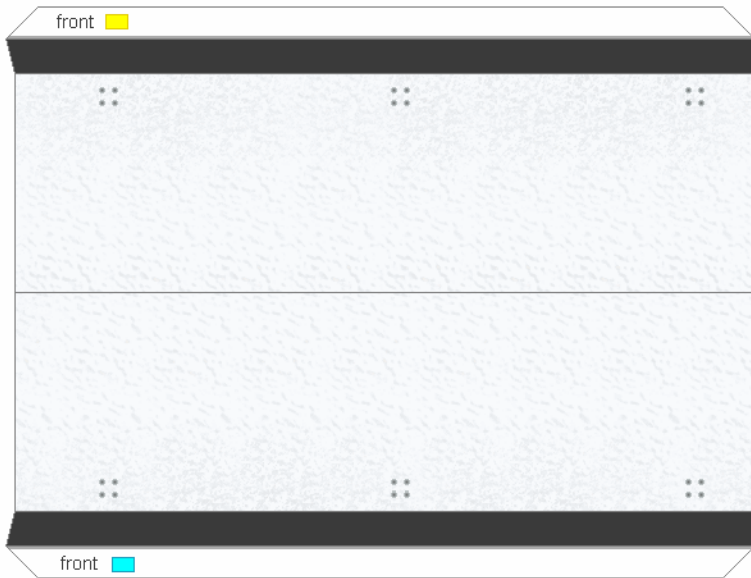

6



30

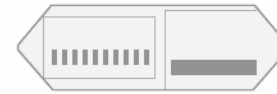

31

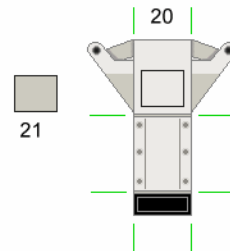

20



21



36

Glue onto cardstock
Make rims black

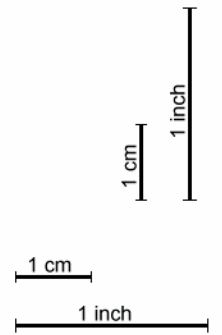

printing calibration

The new space telescope
for infrared observation.



Scale 1:25



Page 5/7

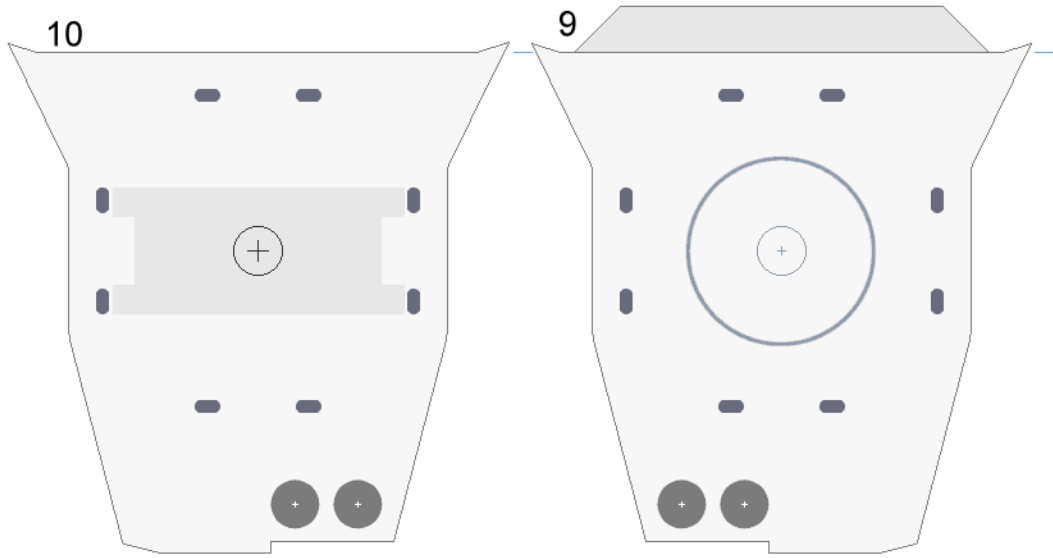

Glue this part onto extra layer of paper.

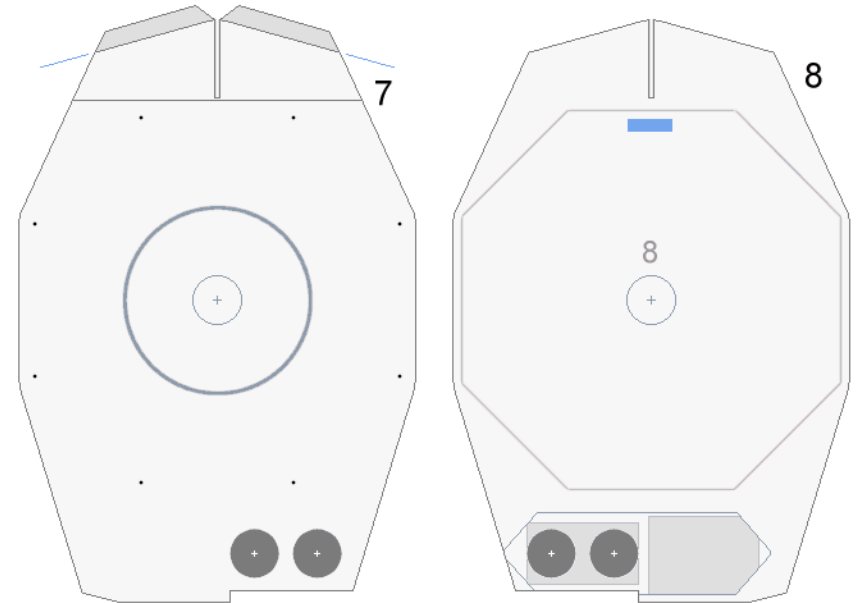

Glue onto cardstock.

Color rims oker yellow or orange-gold.

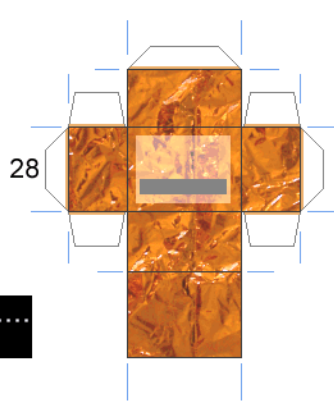
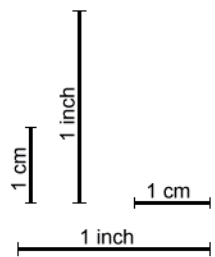

28A

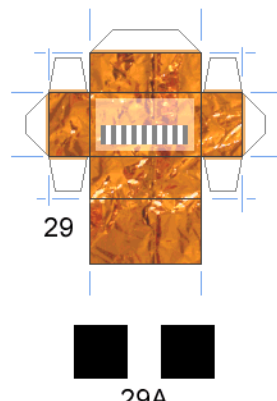

29A

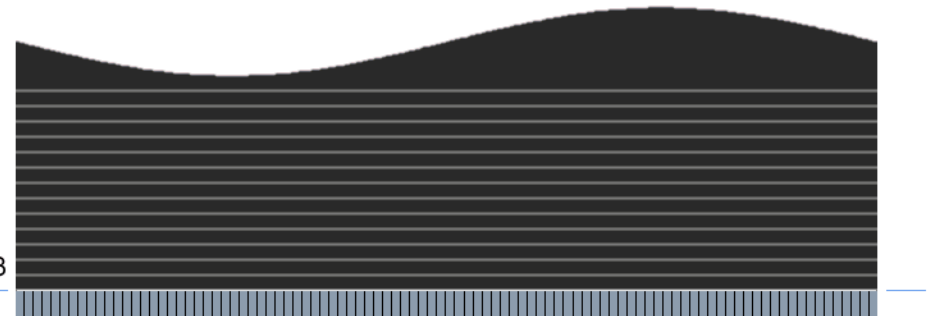

23

The new space telescope
for infrared observation.



Scale 1:25

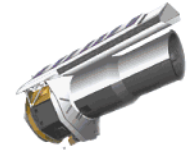

Page 6/7

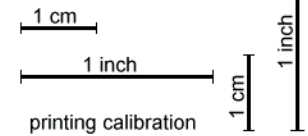
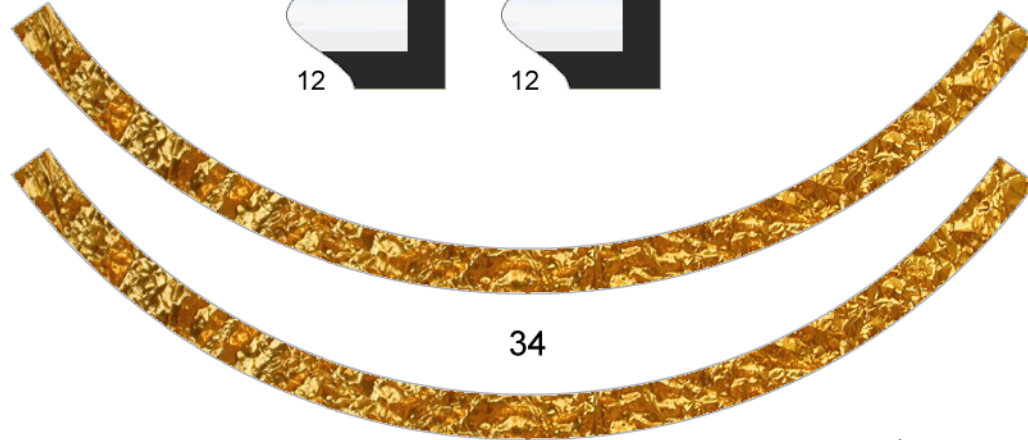
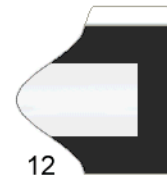
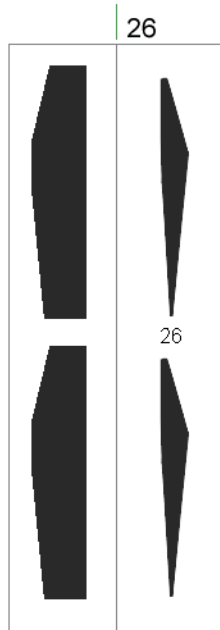
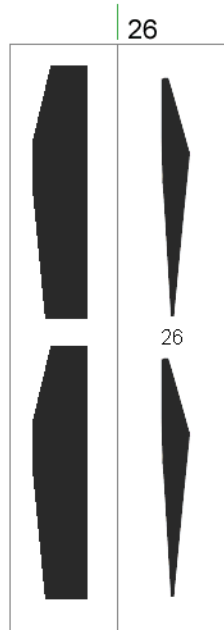
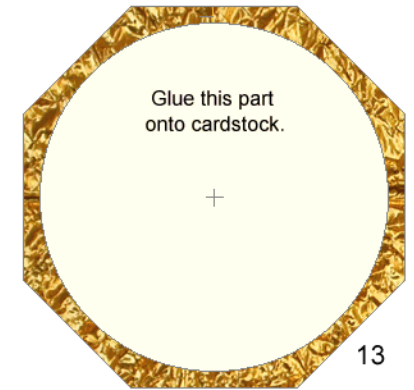
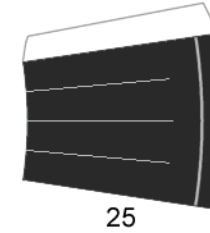
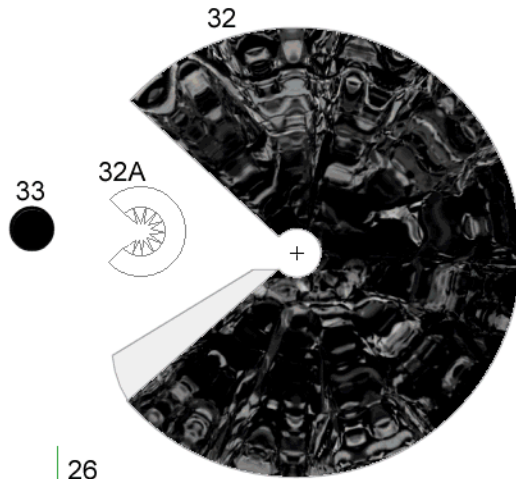
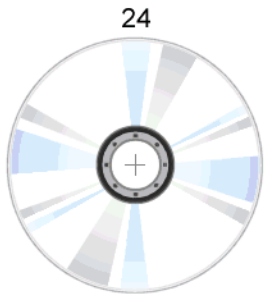

The new space telescope
for infrared observation.



Scale 1:25

Page 7/7

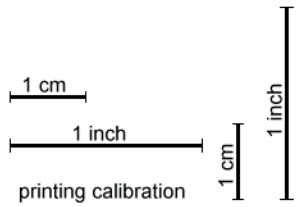
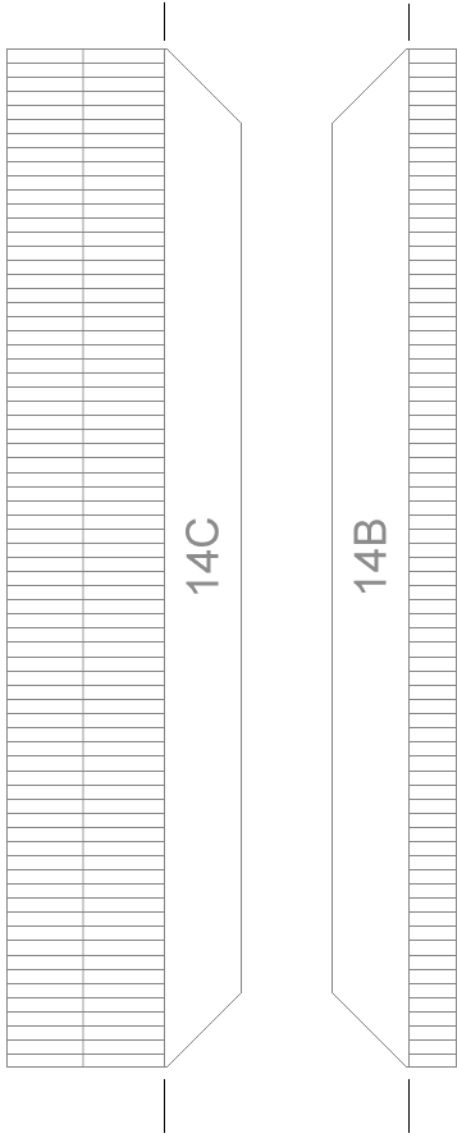

Instructions for building the SIRTf satellite.

What do you need to construct this model ?

- * Sharp scissors
- * A sharp hobby knife
- * A ruler (steel or plastic)
- * A dull knife (or similar) to score the folding lines
- * Glue (waterbased or synthetic)
- * Permanent marker (black)

- * Color crayons
- * Several toothpicks or thin bamboo sticks.

Also important :

- * Patience and the ability to work accurately.

For those who want to add a little extra detail :

- * Self adhesive gold and silver foil (as thin as possible)
- Please refer to the pictures on internet for the correct placement of the foil.

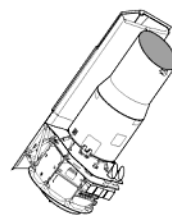

Read these instructions thoroughly and make sure you know what is to be expected. Familiarize yourself with the components and if you can, try to find pictures of SIRTf on internet or in books, to get a better impression of what this spacecraft looks like.

Note from the designer: This paper model is difficult enough as it is. Some parts and ways of construction have been left away or have been simplified. Therefore, some details may vary from details that can be seen in pictures from the real spacecraft.

1

1
2
3
Ink on the inside.

Cut and glue parts 1, 2 and 3.
It is recommended to glue part 2 onto cardboard for extra rigidity. The rest of the model will be mounted to this construction.

2

4 5
Ink on the outside.
Front view

Glue parts 4 and 5 back to back, ink on the outside.

3

6
Ink on the outside.

Cut part 6 and form it as shown.

4

8 7
Thick cardboard

Assemble as shown. Take a thick piece of cardboard and make the entire assembly about 2 mm ... 2.5 mm thick

5

10 9
Use one layer of same type of paper that the model is printed on.

Same situation, but make this assembly about 1 mm 1.3 mm thick.

6

(9+10)

This one will be difficult : making the holes. This is the point where you have to decide if you want to use the struts or not. If you don't, then use parts A and B and do not make the holes.

7

Red stripe 11

Make part 11.
Be careful when scoring the folds. Make them sharp, but don't cut the paper.

8

12
blue stripe

First, make the star trackers (12).
Now, drill the holes until they are big enough for the star tracker to pass through easily. Cut the holes with a sharp, pointed knife. Then use coarse waterproof sanding paper # 80. Use finer paper to make nice round holes and smooth edges.
! Do not glue the star trackers yet ! We'll do that later.

9

13
Red stripe

Glue part 13 into place.
All the small details will be added later.

Instructions for building the SIRTf satellite.

10

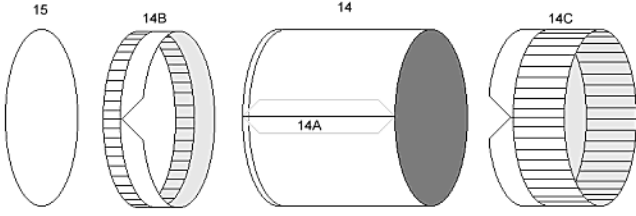

Assemble the rear part of the telescope. Begin with part 14, then add the other parts.

11

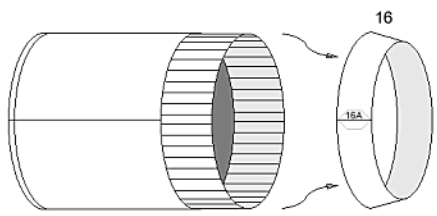

Now assemble part 16 and wait until connector 16A has fully dried. Now carefully bend the flaps of part 14C inward and glue part 16 into place. Once dry bend the remainder of the flaps back outward, pointing straight forward.

12

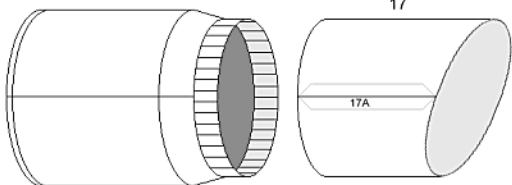

Assemble part 17 and glue into place.
If you want part 23 to fit nicely, it's better to cut a connector out of thin paper. Once part 23 is inserted and glued, the whole assembly will be very firm and strong.

13

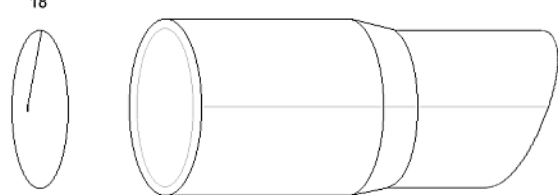

Assemble part 18 and glue into place, with the seam facing up.

14

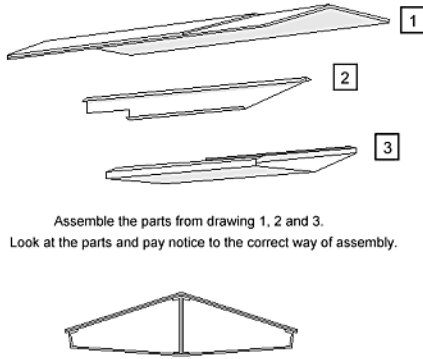

Assemble the parts from drawing 1, 2 and 3. Look at the parts and pay notice to the correct way of assembly.

Front view

15

This is what it should look like.

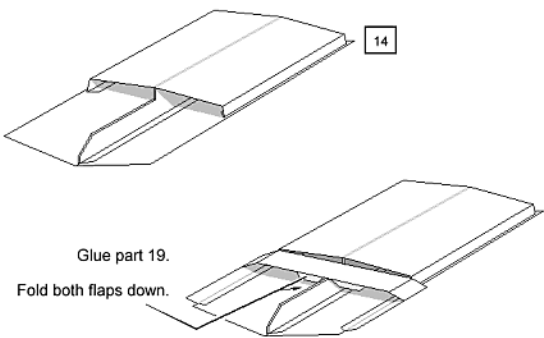

Glue part 19.
Fold both flaps down.

16

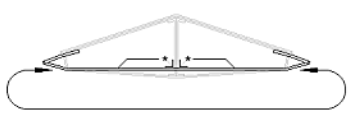

Make sure part 19 is perfectly straight, here.

If not, cut off a piece of part 2 or add 2 small pieces of paper as shown *

17

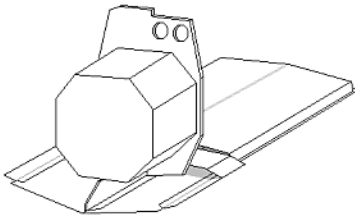

Glue assembly 9 into place.

Would you like this model to stand out ?
You could build another one, but this time you apply silver and gold foil !

Look up the pictures on internet or find some books about this wonderful spacecraft and see where the foil should be applied.

Give it a try ! It's worth the effort !!

Instructions for building the SIRTf satellite.

18

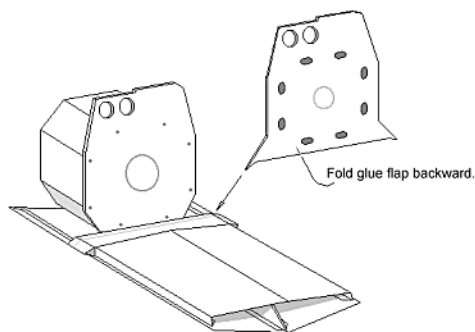

Attention !

Remember that assembling the struts and connecting the telescope to it, later, is difficult and is not recommended for inexperienced modelers.

In the instructions we will continue using the struts on the model.

19

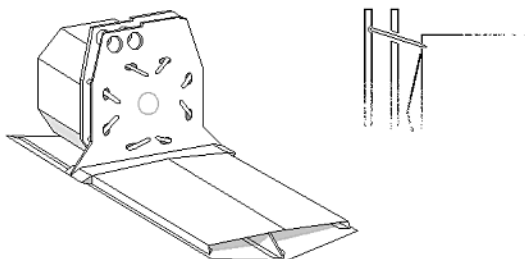
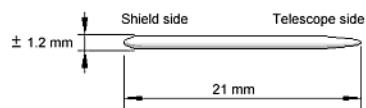

20

Before the telescope can be glued into place, a few more details will have to be added.

If you want to add the other details too, do it now, at this stage.

It's easy to tell by the color where each part should be placed.

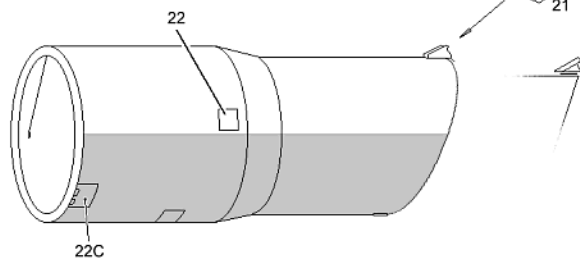

* rings

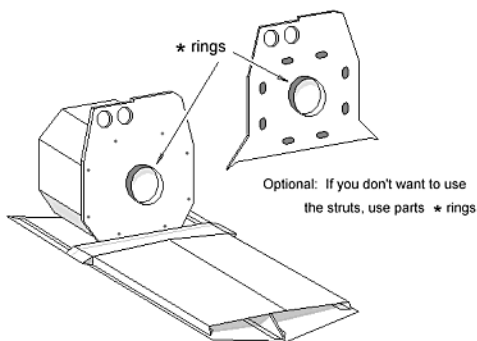

Optional: If you don't want to use the struts, use parts * rings

21

Cut and shape part 23.

22

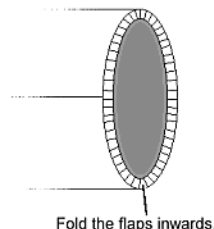
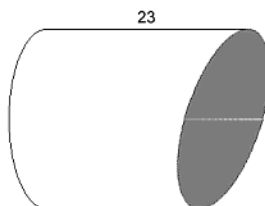
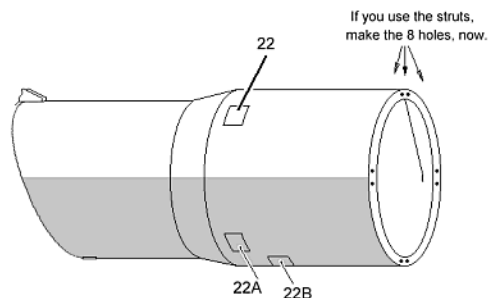

Fold the flaps inward.

23

Insert part 25 as shown.

The white dotted line should be aligned with the surface of the mirror.

24

It's going to have to look like this :

25

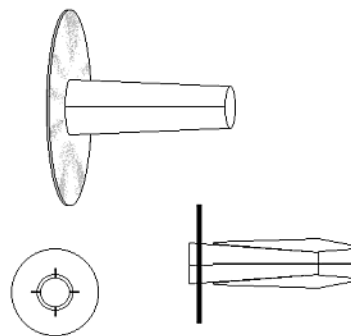
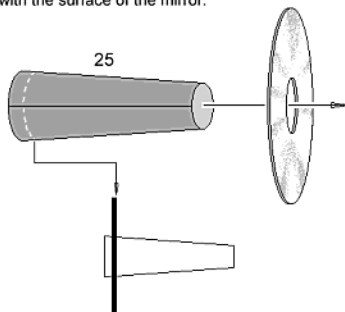
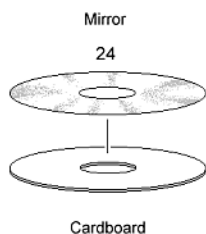

Instructions for building the SIRTF satellite.

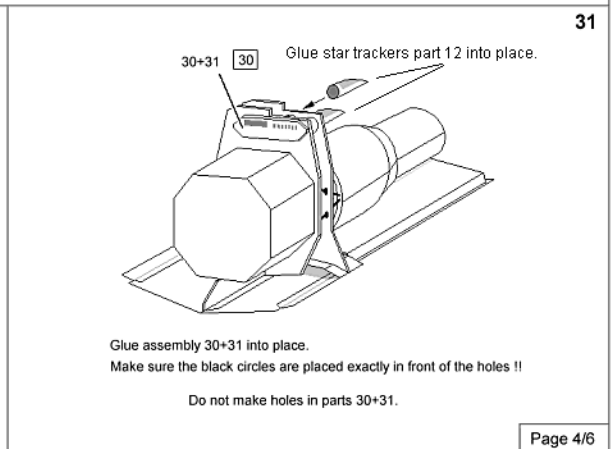
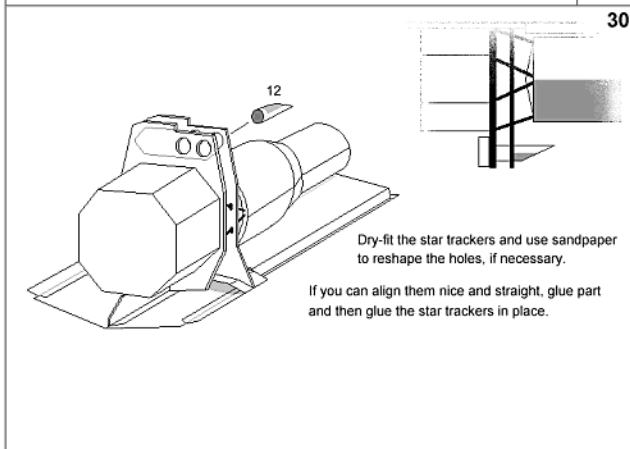
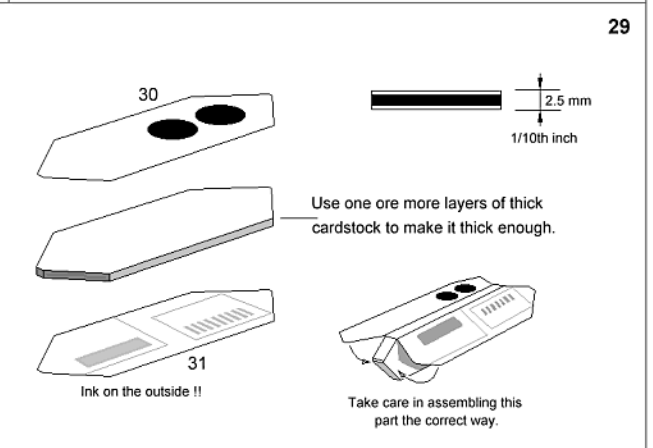
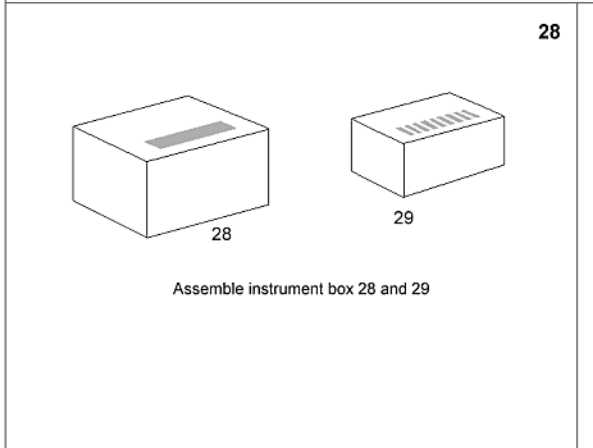
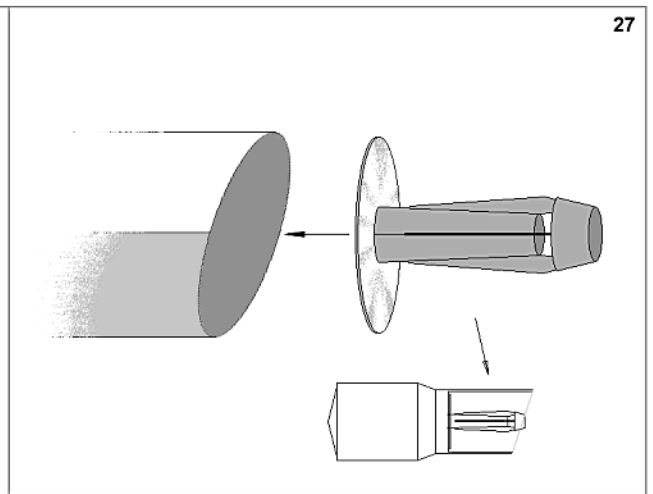
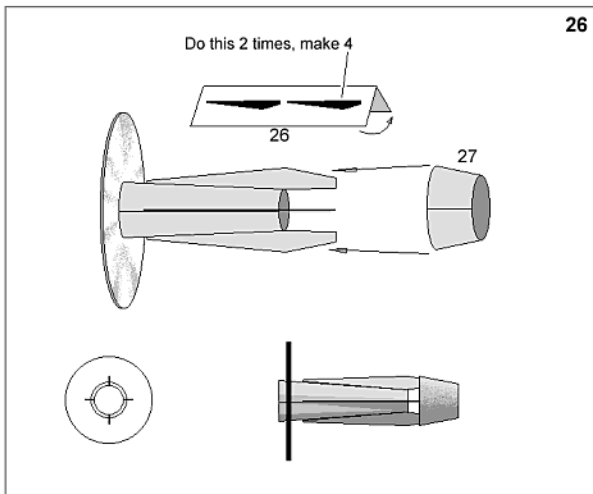

Instructions for building the SIRTF satellite.

32

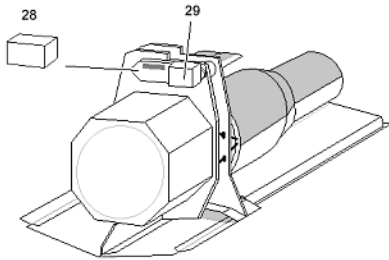

Glue the instrument boxes in place.
Pay attention to the markings so the parts are placed correctly.

33

Glue parts 28A and 29A

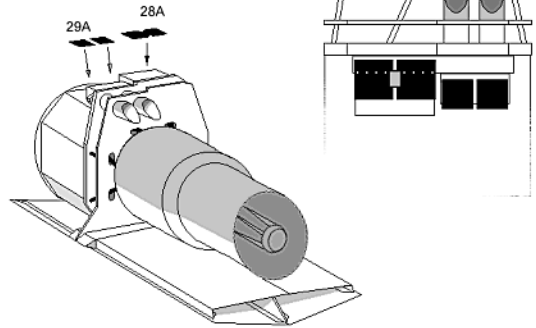

34

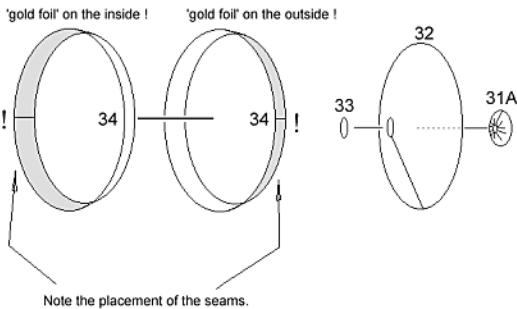

35

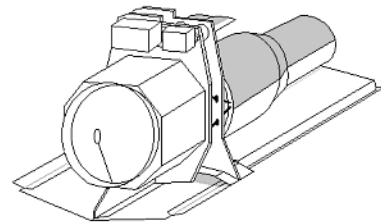

Place part 32 first and center it perfectly, then glue rings 34 into place.

36

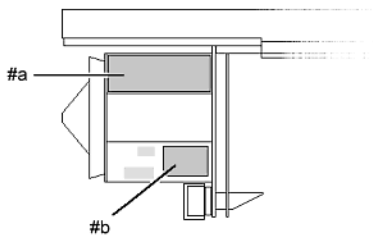

Add parts #a and #b. Part #a is preferably added at stage 9 or 17

37

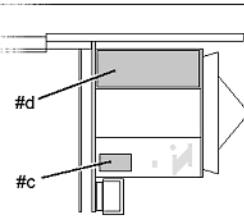

Add parts #c and #d. Part #d is preferably added at stage 9 or 17 .

38

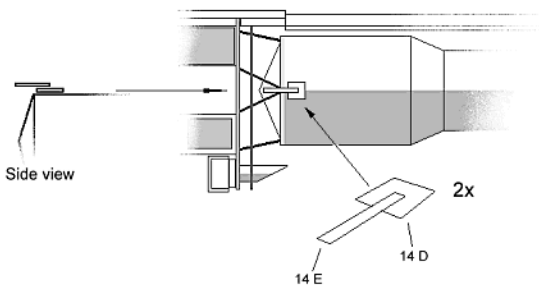

Glue part 14E to 14D, then glue both into place, on both sides.

39

The last part to be assembled :
the dust cover.

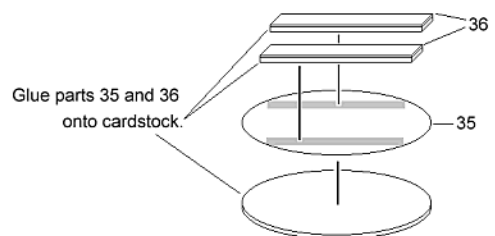

Glue parts 35 and 36 onto cardstock.

Instructions for building the SIRTf satellite.

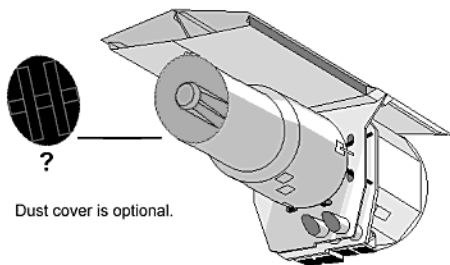

Dust cover is optional.

Your SIRTf model is now finished.

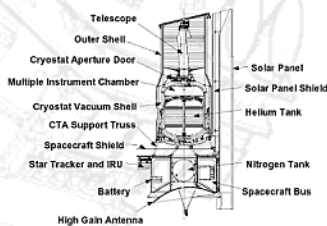
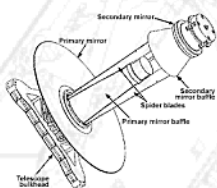
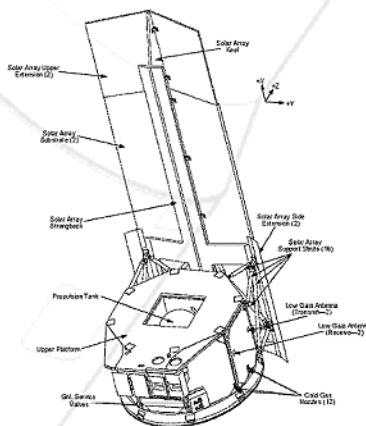
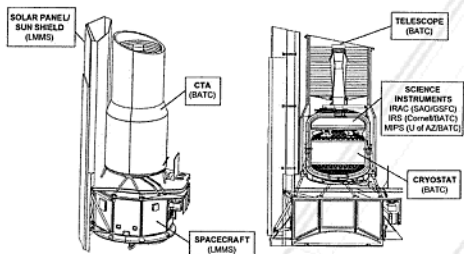
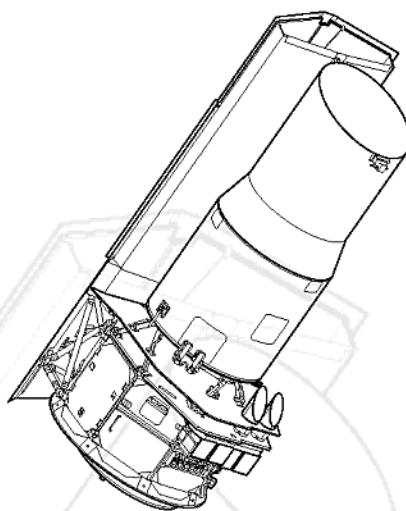

Special thanks to Dr. Robert Hurt from Caltech for helping us to create this paper model .

More models can be found at :

Stichting Volkssterrenwacht
PHILIPPUS LANSBERGEN
<http://www.lansbergen.net>